



November 22, 2021
ES-8218

Earth Solutions NW LLC

Geotechnical Engineering, Construction
Observation/Testing and Environmental Services

2265 LLC
P.O. Box 481
Mercer Island, Washington 98040

Attention: Mr. Jon Friedman

**Subject: Geotechnical Consultation
8005 Southeast 34th Place
Mercer Island, Washington**

Dear Mr. Friedman:

As requested, Earth Solutions NW, LLC (ESNW) has prepared this letter providing a geotechnical assessment and recommendations for the subject site.

Project Description

The subject site is located at 8005 Southeast 34th Place, in Mercer Island, Washington. The property consists of a single residential property located on the southeast corner of the intersection between Southeast 34th Place and 80th Avenue Southeast.

The site is currently developed with a single-family residence and associated infrastructure improvements. We understand the existing residence will be demolished and a new single-family residence and associated improvements will be constructed. The site topography is characterized by a slight southward declivity with total elevation change on the order of about four feet.

Subsurface

The subsurface conditions were explored utilizing hand tools to excavate a series of hand-auger borings on October 18, 2021. A total of three hand-auger borings were excavated in accessible areas of the site, and were advanced to a maximum depth of four feet below the existing surface elevations at the test locations. The approximate locations of the borings are depicted on the Hand Auger Boring Location Plan (Plate 2). Please refer to the attached boring logs for a more detailed description of the subsurface conditions.

Topsoil

Topsoil was encountered at the boring locations, and was observed in thickness of about three inches. Where topsoil is encountered during site grading activities, it is not suitable for use as structural fill nor should it be mixed with material to be used as structural fill. Topsoil or otherwise unsuitable material can be used in landscaping areas if desired.

Fill

Fill soil was not encountered during our fieldwork. Fill soil may likely be present surrounding the existing buildings and other improvements, and will require an assessment by a geotechnical professional for use as structural fill material.

Native Soil

Underlying the topsoil at the test locations, native soils consisting of silty sand (Unified Soil Classification SM), were encountered. The silty sand soils were observed in a medium dense condition. These soil types were observed extending to the maximum exploration depth. The soil density was observed to increase with depth.

Groundwater

Groundwater seepage was not observed at the test locations during the fieldwork; however, seepage should be expected in excavations at this site, particularly during the winter, spring, and early summer months. Groundwater seepage rates and elevations fluctuate depending on many factors, including precipitation duration and intensity, the time of year, and soil conditions. In general, groundwater flow rates are higher during the wetter, winter months.

Geologic Setting

Based on review of geologic mapping for the Mercer Island area, the site is located in a zone comprised of Pre-Olympia fine grained glacial (Qpogf) deposits.

The referenced SCS soil survey describes Kitsap Silt loam, 15 to 30 percent slopes (KpD,) series soils for the site and surrounding area. This series of soils are typified by lacustrine deposits. The native soil observed at the hand-auger boring locations are consistent with lacustrine deposits.

Recommendations

Based on the hand-auger boring data, geotechnical recommendations for the project are provided below.

ESNW should provide field observations and recommendations during the construction phase of the project.

Site Preparation and Earthwork

Site preparation activities will involve demolition of the existing structure(s), site clearing and stripping, and implementation of temporary erosion control measures. The primary geotechnical considerations associated with site preparation activities include installation of erosion control measures and building pad subgrade preparation.

Temporary construction entrances and drive lanes, consisting of at least six inches of quarry spalls (potentially placed over geotextile) can be considered in order to minimize off-site soil tracking and to provide a stable access entrance surface. Erosion control measures should consist of silt fencing placed along the down gradient side of the site. Soil stockpiles should be covered or otherwise protected to reduce soil erosion. Temporary sedimentation ponds or other approaches for controlling surface water runoff should be in place prior to beginning earthwork activities.

Where encountered, topsoil and organic-rich soil is not suitable for foundation support, nor is it suitable for use as structural fill. Topsoil or organic-rich soil can be used in non-structural areas if desired. Over-stripping of the site, however, should be avoided. A representative of ESNW should observe the initial stripping operations, to provide recommendations for stripping depths based on the soil conditions exposed during stripping.

Structural fill soils placed throughout foundation, slab, and pavement areas should be placed over a firm base. Loose or otherwise unsuitable areas of native soil exposed at subgrade elevations should be compacted to structural fill requirements or overexcavated and replaced with a suitable structural fill material. Where structural fill soils are used to construct foundation subgrade areas, the soil should be compacted to the requirements of structural fill described in the following section. Foundation subgrade areas should be protected from disturbance, construction traffic, and excessive moisture. Where instability develops below structural fill areas, use of a woven geotextile below the structural fill areas may be required. A representative of ESNW should observe structural fill placement in foundation, slab, and pavement areas.

The process of removing existing structures may produce voids where foundations and basements are present. Complete restoration of voids caused by the removal of existing structure must be executed as part of overall subgrade and building pad preparation activities, unless the excavation for the new building will be lower than existing basements.

The following guidelines for preparing building subgrade areas should be incorporated into the final design:

- Removal of the existing stem walls to an elevation where a four-foot vertical separation between the bottom of new foundations is maintained, and demolition of the slab present in the existing basement, or;
- Complete removal of all foundation elements, stem walls, footing drains, sewer and storm drainage pipes, etc. within the footprint of the existing structure.
- Where voids and related demolition disturbances extend below planned subgrade elevations, restoration of these areas should be completed. Structural fill should be used to restore voids or unstable areas resulting from the removal of existing structural improvements.
- Where pipes for stormwater and sanitary sewer are encountered, they should be plugged and abandoned.
- Recompact, or overexcavate and replace, areas of existing fill, if present, exposed at building subgrade elevations. ESNW should confirm subgrade conditions and the required level of recompaction, or overexcavation and replacement, during site preparation activities. Overexcavations should extend into competent native soils, and structural fill should be used to restore subgrades areas.
- ESNW should confirm the overall suitability of prepared subgrade areas following site preparation activities.

In-situ Soils

The soils encountered at the boring sites have a moderate to high sensitivity to moisture and were generally in a moist condition at the time of the exploration (October 2021). In this respect, the in-situ soils may not be suitable for use as structural fill if the soil moisture content is more than about 3 percent above the optimum level at the time of construction in the case of the silty sand soils. In general, soils encountered during the site excavations that are excessively over the optimum moisture content will require moisture conditioning prior to placement and compaction. Conversely, soils that are below the optimum moisture content will require moisture conditioning through the addition of water prior to use as structural fill. If the in-situ soils are determined to not be suitable for use as structural fill, then use of a suitable imported soil may be necessary. In our opinion, a contingency should be included in the project budget for exporting unsuitable soil and importing structural fill; or moisture conditioning recommendations can be provided upon request based on field observations during the construction phase of on-site work.

A one-third increase in the allowable soil bearing capacity can be assumed for short-term wind and seismic loading conditions. The above passive pressure and friction values include a factor-of-safety of 1.5. With structural loading as expected, total settlement in the range of one inch and differential settlement of about one-half inch is anticipated. The majority of the settlements should occur during construction, as dead loads are applied.

Given the site soil conditions, footing drains should be installed adjacent to new footings.

Where site work will include preparation of the foundation subgrade during the wet-season, we recommend the site developer be prepared to place crushed rock in the foundation excavations to act as a working surface and to protect the subgrade from disturbance.

Seismic Design Considerations

The 2018 International Building Code (2018 IBC) recognizes the most recent edition of the Minimum Design Loads for Buildings and Other Structures manual (ASCE 7-16) for seismic design, specifically with respect to earthquake loads. Based on the soil conditions encountered at the test pit locations, the parameters and values provided below are recommended for seismic design per the 2018 IBC.

Parameter	Value
Site Class	D*
Mapped short period spectral response acceleration, $S_s (g)$	1.406
Mapped 1-second period spectral response acceleration, $S_1 (g)$	0.489
Short period site coefficient, F_a	1.0
Long period site coefficient, F_v	1.811
Adjusted short period spectral response acceleration, $S_{MS} (g)$	1.406
Adjusted 1-second period spectral response acceleration, $S_{M1} (g)$	0.885
Design short period spectral response acceleration, $S_{DS} (g)$.937
Design 1-second period spectral response acceleration, $S_{D1} (g)$	0.590

* Assumes dense soil conditions, encountered to a maximum depth of four feet bgs during the October of 2021 field exploration, remain medium dense to at least 100 feet bgs. Based on our experience with the project geologic setting (lacustrine sediments) across the Puget Sound region, soil conditions are likely consistent with this assumption.

Further discussion between the project structural engineer, the project owner (or their representative), and ESNW may be prudent to determine the possible impacts to the structural design due to increased earthquake load requirements under the 2018 IBC. ESNW can provide additional consulting services to aid with design efforts, including supplementary geotechnical and geophysical investigation, upon request.

Liquefaction is a phenomenon where saturated or loose soil suddenly loses internal strength and behaves as a fluid. This behavior is in response to increased pore water pressures resulting from an earthquake or another intense ground shaking. In our opinion, site susceptibility to liquefaction may be considered negligible. The relative density of the native soil underlying the site is the basis for this opinion.

Slab-On-Grade Floors

Slab-on-grade floors should be supported on a suitable capillary break material underlain by undisturbed, competent native soil or at least one foot of compacted structural fill subgrade. A capillary break consisting of a minimum of four inches of free-draining crushed rock or gravel should be placed below the slab. The free-draining material should have a fines content of 5 percent or less defined as the percent passing the Number 200 sieve, based on the minus three-quarter inch fraction. In areas where slab moisture is undesirable, installation of a vapor barrier below the slab should be considered. If used, the vapor barrier should consist of a material specifically designed to function as a vapor barrier and should be installed in accordance with the manufacturer's specifications.

Retaining Walls

Retaining walls must be designed to resist earth pressures and applicable surcharge loads. The following parameters can be used for retaining wall design:

- Active earth pressure (unrestrained condition) 35 pcf
- At-rest earth pressure (restrained condition) 55 pcf
- Traffic surcharge (passenger vehicles) 70 psf (rectangular distribution)
- Passive earth pressure 300 pcf
- Coefficient of friction 0.40
- Seismic surcharge 8H*

* Where H equals the retained height.

The passive earth pressure and coefficient of friction values include a safety factor of 1.5. Additional surcharge loading from adjacent foundations, sloped backfill, or other loads should be included in the retaining wall design. Drainage should be provided behind retaining walls such that hydrostatic pressures do not develop. If drainage is not provided, hydrostatic pressures should be included in the wall design.

Retaining walls should be backfilled with free-draining material that extends along the height of the wall, and a distance of at least 18 inches behind the wall; a drainage mat can be considered in lieu of the free-draining material. The upper one foot of the wall backfill can consist of a less permeable soil, if desired. A perforated drain pipe should be placed along the base of the wall, and connected to an approved discharge location. A typical footing drain detail is provided on Plate 3.

Drainage

Seepage will likely be encountered in excavations on the site, particularly during winter, spring, and early summer months. Temporary measures to control surface water runoff and groundwater during construction would likely involve interceptor trenches and sumps. ESNW should be consulted during preliminary grading to identify areas of seepage and to provide recommendations to reduce the potential for instability related to seepage effects.

Finish grades must slope away from the residences at an inclination of at least 2 percent for a distance of at least ten feet or as adjacent structures allow. In addition, surface water should be controlled utilizing best management practices (BMP) during, and after, construction on the subject site. Given the site soil conditions, footing drains should be installed around the perimeter of buildings. A typical foundation drain detail is provided as Plate 3.

Infiltration Evaluation

The subject site is underlain by silty lacustrine deposits which typically have a very low to no infiltration capacity. In addition, mottling (indicative of groundwater seepage) was observed at depths of approximately three feet below existing grades. These sediments represent a confining layer of material within the subgrade which severely retards stormwater infiltration, if not nullifies it.

In our opinion, an alternative methodology to full infiltration for control of stormwater should be considered on the site.

Excavations and Slopes

The Federal Occupation Safety and Health Administration (OSHA) and the Washington Industrial Safety and Health Act (WISHA) provide soil classification in terms of temporary slope inclinations. Based on the soil conditions encountered at the test locations, existing fill, loose native soil, recessional sands, and any soil where groundwater seepage is exposed, are classified as Type C by OSHA/WISHA. Temporary slopes over four feet in height in Type C soils must be sloped no steeper than 1.5H:1V (Horizontal:Vertical). The presence of perched groundwater may cause caving of the temporary slopes due to hydrostatic pressure. The native silty sand soils observed are classified as Type B. Temporary slopes over four feet in height in Type B soils must be sloped no steeper than 1H:1V. Temporary excavations with inclinations steeper than those described may be acceptable from a geotechnical standpoint. ESNW should be consulted during the design phase to provide recommendations for steeper temporary excavations if necessary. ESNW should observe site excavations to confirm the soil type and allowable slope inclination. If the recommended temporary slope inclination cannot be achieved, temporary shoring may be necessary to support excavations.

Permanent slopes should maintain a gradient of 2H:1V, or flatter, and should be planted with vegetation to enhance stability and to minimize erosion. A representative of ESNW should observe temporary and permanent slopes to confirm the slope inclinations, and to provide additional excavation and slope recommendations, as necessary.

Limitations

The recommendations and conclusions provided in this letter are professional opinions consistent with the level of care and skill that is typical of other members in the profession currently practicing under similar conditions in this area. Our recommendations are based on the information available at the time of this letter preparation. A warranty is not expressed or implied.

If you have any questions, or if additional information is required, please call.

Sincerely,

EARTH SOLUTIONS NW, LLC

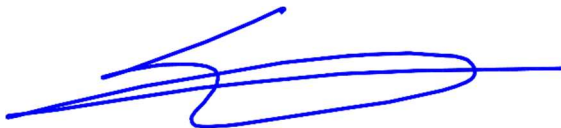

Stephen H. Avril
Senior Project Geologist

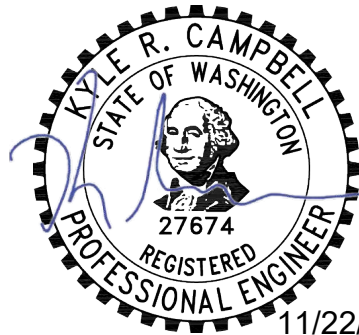

11/22/2021

Kyle R. Campbell, P.E.
Principal Engineer

- Attachments: Plate 1 – Vicinity Map
Plate 2 – Hand Auger Boring Location Plan
Plate 3 – Footing Drain Detail
Hand Auger Boring Logs



Reference:
King County, Washington
OpenStreetMap.org



NOTE: This plate may contain areas of color. ESNW cannot be responsible for any subsequent misinterpretation of the information resulting from black & white reproductions of this plate.

Earth Solutions NW LLC

Geotechnical Engineering, Construction
Observation/Testing and Environmental Services

Vicinity Map
8005 S.E. 34th Place Property
Mercer Island, Washington

Drwn. CAM	Date 11/18/2021	Proj. No. 8218
Checked SHA	Date Nov. 2021	Plate 1

S.E. 34TH PLACE

80TH AVENUE S.E.

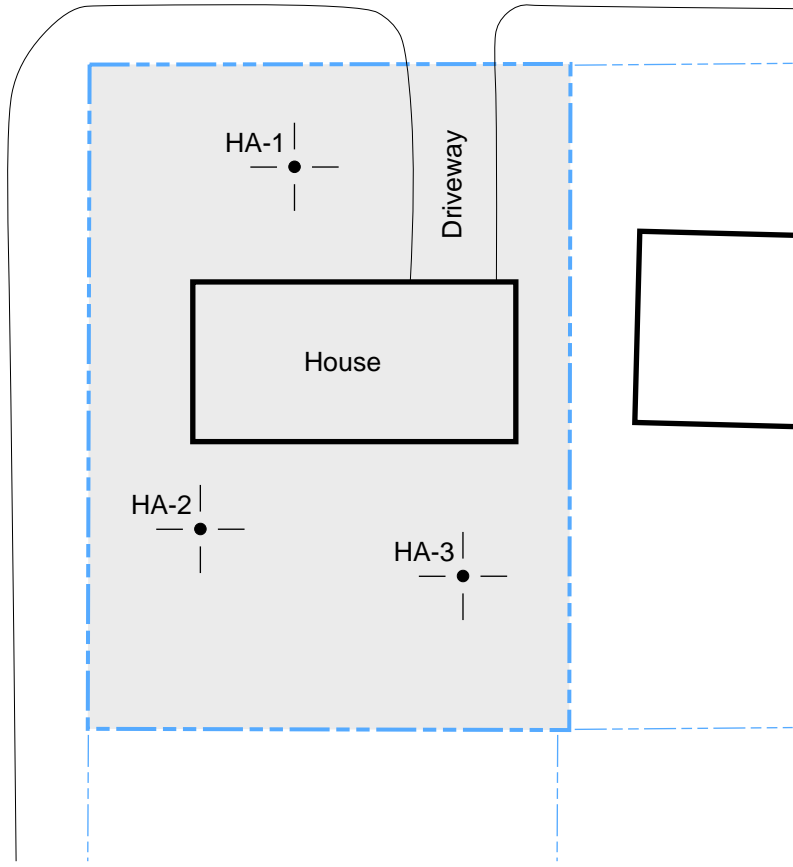

LEGEND

HA-1 |
 — ● —
 |
 Approximate Location of
 ESNW Hand Auger Boring,
 Proj. No. ES-8218, Oct. 2021

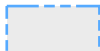
 Subject Site

 Existing Building



NOT - TO - SCALE

NOTE: The graphics shown on this plate are not intended for design purposes or precise scale measurements, but only to illustrate the approximate test locations relative to the approximate locations of existing and / or proposed site features. The information illustrated is largely based on data provided by the client at the time of our study. ESNW cannot be responsible for subsequent design changes or interpretation of the data by others.

NOTE: This plate may contain areas of color. ESNW cannot be responsible for any subsequent misinterpretation of the information resulting from black & white reproductions of this plate.



Earth Solutions NW_{LLC}
 Geotechnical Engineering, Construction
 Observation/Testing and Environmental Services

**Hand Auger Boring Location Plan
 8005 S.E. 34th Place Property
 Mercer Island, Washington**

Drwn. CAM	Date 11/18/2021	Proj. No. 8218
Checked SHA	Date Nov. 2021	Plate 2

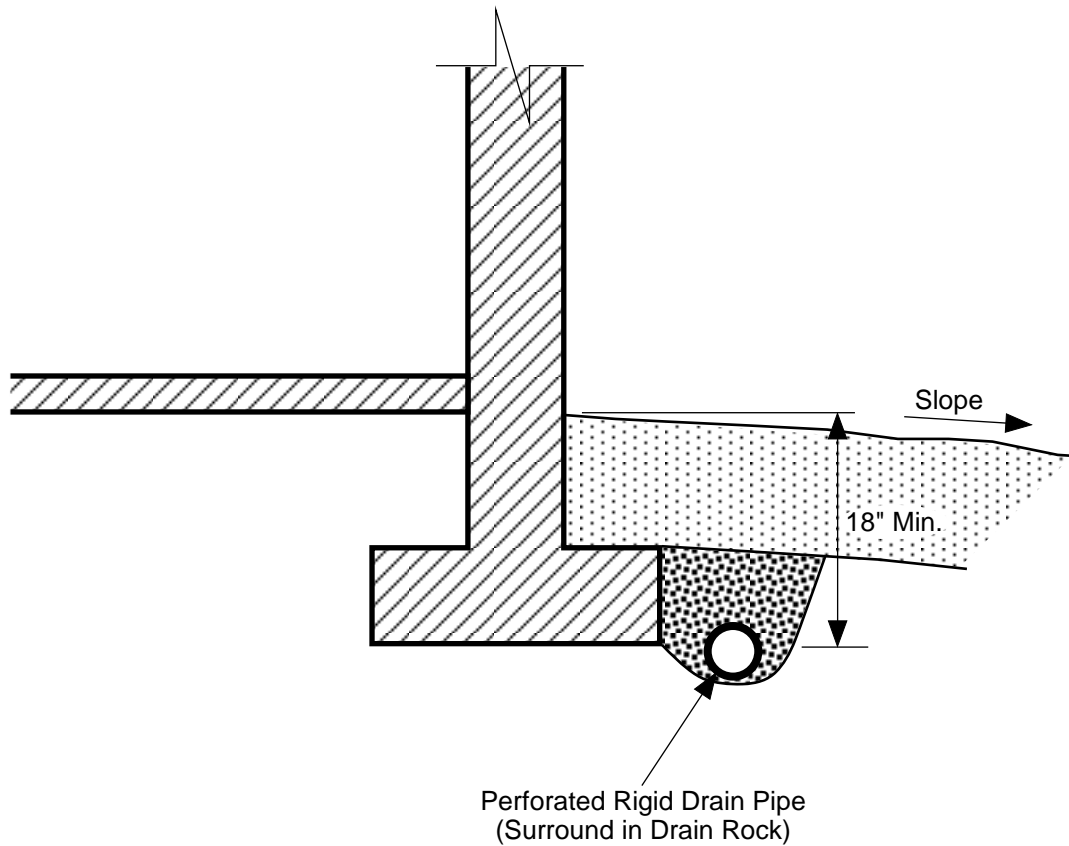

NOTES:

- Do NOT tie roof downspouts to Footing Drain.
- Surface Seal to consist of 12" of less permeable, suitable soil. Slope away from building.

SCHMATIC ONLY - NOT TO SCALE
NOT A CONSTRUCTION DRAWING

LEGEND:

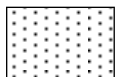
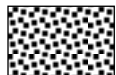
-  Surface Seal: native soil or other low-permeability material.
-  1-inch Drain Rock

		Earth Solutions NW_{LLC} Geotechnical Engineering, Construction Observation/Testing and Environmental Services	
Footing Drain Detail 8005 S.E. 34th Place Property Mercer Island, Washington			
Drwn. CAM	Date 11/22/2021	Proj. No. 8218	
Checked SHA	Date Nov. 2021	Plate 3	

Earth Solutions NW_{LLC}

SOIL CLASSIFICATION CHART

MAJOR DIVISIONS			SYMBOLS		TYPICAL DESCRIPTIONS	
			GRAPH	LETTER		
<p>COARSE GRAINED SOILS</p> <p>MORE THAN 50% OF MATERIAL IS LARGER THAN NO. 200 SIEVE SIZE</p>	<p>GRAVEL AND GRAVELLY SOILS</p>	<p>CLEAN GRAVELS</p> <p>(LITTLE OR NO FINES)</p>		GW	WELL-GRADED GRAVELS, GRAVEL - SAND MIXTURES, LITTLE OR NO FINES	
		<p>GRAVELS WITH FINES</p> <p>(APPRECIABLE AMOUNT OF FINES)</p>		GP	POORLY-GRADED GRAVELS, GRAVEL - SAND MIXTURES, LITTLE OR NO FINES	
		<p>GRAVELS WITH FINES</p> <p>(APPRECIABLE AMOUNT OF FINES)</p>		GM	SILTY GRAVELS, GRAVEL - SAND - SILT MIXTURES	
		<p>GRAVELS WITH FINES</p> <p>(APPRECIABLE AMOUNT OF FINES)</p>		GC	CLAYEY GRAVELS, GRAVEL - SAND - CLAY MIXTURES	
	<p>SAND AND SANDY SOILS</p>	<p>CLEAN SANDS</p> <p>(LITTLE OR NO FINES)</p>		SW	WELL-GRADED SANDS, GRAVELLY SANDS, LITTLE OR NO FINES	
				SP	POORLY-GRADED SANDS, GRAVELLY SAND, LITTLE OR NO FINES	
		<p>SANDS WITH FINES</p> <p>(APPRECIABLE AMOUNT OF FINES)</p>		SM	SILTY SANDS, SAND - SILT MIXTURES	
				SC	CLAYEY SANDS, SAND - CLAY MIXTURES	
			<p>SILTS AND CLAYS</p> <p>LIQUID LIMIT LESS THAN 50</p>		ML	INORGANIC SILTS AND VERY FINE SANDS, ROCK FLOUR, SILTY OR CLAYEY FINE SANDS OR CLAYEY SILTS WITH SLIGHT PLASTICITY
					CL	INORGANIC CLAYS OF LOW TO MEDIUM PLASTICITY, GRAVELLY CLAYS, SANDY CLAYS, SILTY CLAYS, LEAN CLAYS
<p>SILTS AND CLAYS</p> <p>LIQUID LIMIT GREATER THAN 50</p>		OL	ORGANIC SILTS AND ORGANIC SILTY CLAYS OF LOW PLASTICITY			
		MH	INORGANIC SILTS, MICACEOUS OR DIATOMACEOUS FINE SAND OR SILTY SOILS			
		CH	INORGANIC CLAYS OF HIGH PLASTICITY			
		OH	ORGANIC CLAYS OF MEDIUM TO HIGH PLASTICITY, ORGANIC SILTS			
<p>HIGHLY ORGANIC SOILS</p>				PT	PEAT, HUMUS, SWAMP SOILS WITH HIGH ORGANIC CONTENTS	

DUAL SYMBOLS are used to indicate borderline soil classifications.

The discussion in the text of this report is necessary for a proper understanding of the nature of the material presented in the attached logs.



Earth Solutions NW, LLC
 15365 N.E. 90th Street, Suite 100
 Redmond, Washington 98052
 Telephone: 425-449-4704
 Fax: 425-449-4711

PROJECT NUMBER ES-8218 PROJECT NAME 8005 S.E. 34th Place Property
 DATE STARTED 10/18/21 COMPLETED 10/18/21 GROUND ELEVATION _____
 DRILLING CONTRACTOR ESNW Rep LATITUDE 47.57966 LONGITUDE -122.23208
 DRILLING METHOD Hand Auger GROUND WATER LEVEL: _____
 LOGGED BY SES CHECKED BY SHA AT TIME OF DRILLING _____
 NOTES Depth of Topsoil & Sod 3": grass

DEPTH (ft)	SAMPLE TYPE NUMBER	TESTS	U.S.C.S.	GRAPHIC LOG	MATERIAL DESCRIPTION
0					
		MC = 17.6%	SM		Brown silty SAND, medium dense, wet -root intrusions to 2'
		MC = 14.4% Fines = 58.1%	ML		Gray sandy SILT, medium dense, moist -mottled texture [USDA Classification: slightly gravelly LOAM]

Hand auger boring terminated at 4.0 feet below existing grade. No groundwater encountered during excavation. No caving observed.



Earth Solutions NW, LLC
 15365 N.E. 90th Street, Suite 100
 Redmond, Washington 98052
 Telephone: 425-449-4704
 Fax: 425-449-4711

BORING NUMBER HA-2

PROJECT NUMBER ES-8218 PROJECT NAME 8005 S.E. 34th Place Property
 DATE STARTED 10/18/21 COMPLETED 10/18/21 GROUND ELEVATION _____
 DRILLING CONTRACTOR ESNW Rep LATITUDE 47.57947 LONGITUDE -122.23213
 DRILLING METHOD Hand Auger GROUND WATER LEVEL:
 LOGGED BY SES CHECKED BY SHA AT TIME OF DRILLING _____
 NOTES Depth of Topsoil & Sod 3": grass

DEPTH (ft)	SAMPLE TYPE NUMBER	TESTS	U.S.C.S.	GRAPHIC LOG	MATERIAL DESCRIPTION
0					
		MC = 24.8% Fines = 43.8%	SM		Brown silty SAND, medium dense, wet [USDA Classification: gravelly LOAM]
		MC = 13.2%	ML		Gray sandy SILT, medium dense, moist -mottled texture

Hand auger boring terminated at 4.0 feet below existing grade. No groundwater encountered during excavation. No caving observed.



Earth Solutions NW, LLC
 15365 N.E. 90th Street, Suite 100
 Redmond, Washington 98052
 Telephone: 425-449-4704
 Fax: 425-449-4711

PROJECT NUMBER ES-8218 PROJECT NAME 8005 S.E. 34th Place Property
 DATE STARTED 10/18/21 COMPLETED 10/18/21 GROUND ELEVATION _____
 DRILLING CONTRACTOR ESNW Rep LATITUDE 47.57945 LONGITUDE -122.2319
 DRILLING METHOD Hand Auger GROUND WATER LEVEL:
 LOGGED BY SES CHECKED BY SHA AT TIME OF DRILLING _____
 NOTES Depth of Topsoil & Sod 3": grass

DEPTH (ft)	SAMPLE TYPE NUMBER	TESTS	U.S.C.S.	GRAPHIC LOG	MATERIAL DESCRIPTION
0					
			SM		Brown silty SAND, medium dense, wet
		MC = 21.3%		3.5	

Hand auger boring terminated at 3.5 feet below existing grade. No groundwater encountered during excavation. No caving observed.